

U2 Smart / U2 ProS / U2 Diesel / U2 SmartOne” Product Manual

Version 1.4 June 2021

Copyright 2020 ANSER Coding Inc. The information contained herein is subject to change without notice. Reproduction, adaptation or translation without prior written permission is prohibited, except as allowed under the copyright laws.

1. ANSER Ink Jet Printer Components	5
1.1 Thermal Ink Jet (TIJ) Technology	6
1.2 ANSER TIJ inkjet printer portfolio	6
2. ANSER Ink Jet Printer Components	7
2.1 Printer Main Unit.....	8
2.2 Pocket-size Remote Keypad.....	10
2.3 Printer Assembly Kit.....	12
3. Installation	13
3.1 Printer Mounting Direction.....	14
3.2 Cartridge Insert & Remove	15
3.3 Printer Startup & Shutdown	16
3.3.1 Printer Startup	16
3.3.2 Printer Shutdown.....	17
4. User Interface Operation	18
4.1 Home Page.....	19
4.1.1 Status Bar	20
4.1.2 Print Preview	22
4.1.3 Real-Time Printing Report.....	22
4.2 Menu Settings Page	23
4.3 Editor.....	23
4.3.1 Message Selection and Printing.....	24
4.3.2 Adding New Message.....	24
4.3.3 Edit Message	26

4.3.4	Message Delay	31
4.3.5	Copy Message	31
4.3.6	Delete Message	31
4.3.7	Search Message	31
4.3.8	Loop Message	32
4.4	Editor Settings	33
4.4.1	Global Shift Table	33
4.4.2	Global String Table	33
4.4.3	Pre-Zero Format	33
4.4.4	Custom Year	34
4.5	System Settings	35
4.5.1	General Settings	35
4.5.2	Printhead Settings	37
4.5.3	Device Settings	38
4.5.4	Display Settings	39
4.5.5	Sound Settings	39
4.5.6	Printer Status	39
4.6	Function Tree	41
5.	Additional Printer Operations	42
5.1	Printer Software Update	43
5.2	RS232 Data Management	43
5.2.1	RS232 Port Settings	43
5.2.2	RS232 Data management	44
6.	MessagePRO II PC Client Software	46
6.1	USB Sync Function	47
6.2	Edit Message	47

6.3 Software Description	47
7. Optional Accessories	48
7.1 External Photocell	49
7.2 External Encoder	49
7.3 Alarm Kit	50
7.4 Photocell and Encoder Installation	51
7.5 Sensors and Alarm Kit Installation	51
8. Daily Protection and Maintenance	52
8.1 Cartridge Maintenance	53
8.2 Periodic Time Adjustment	53
8.3 Printer Maintenance	53
9. Troubleshooting	54
9.1 Encoder Setting Problem	55
9.2 Photocell Setting Problem	55
10. Specification	56
10.1 U2 Ink Jet Printer	57
10.2 External Photocell	58
10.3 External Encoder	59
10.4 Alarm Kit	60
10.5 Expansion Kit Box	61
11. Installation / Operation Precautions	62
11.1 Installation Precautions	63
11.2 Operation Precautions	63

1. ANSER Ink Jet Printer Components

This section will cover brief introduction of:

1.1 Thermal Ink Jet (TIJ) Technology

1.2 ANSER TIJ inkjet printer portfolio

1.1 Thermal Ink Jet (TIJ) Technology

TIJ technology uses a drop ejection process, storing ink in a cartridge that regulates the pressure of the fluid. Inks are then delivered to the firing chamber to be heated at more than 1,000,000 C/second by an electric resistor. A 0.1 micrometer thick film of ink is heated to around 340C, from which a bubble is formed to expel the ink. A droplet breaks away from this bubble causing it to collapse, the firing chamber then refills as the whole process repeats.

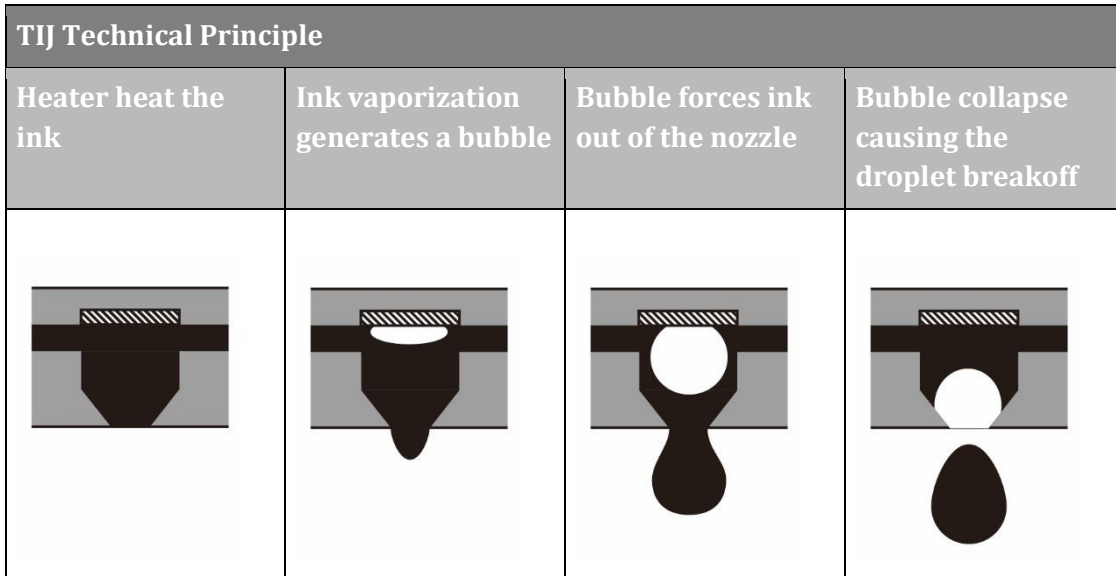

1.2 ANSER TIJ inkjet printer portfolio

ANSER provide wide range of TIJ printing solution suitable for your ever-increasing coding demand....

	Substrate Type *		
	Porous	Semi Porous	Non-Porous
U2 Smart	c	c	
U2 SmartONE™	c	c	
U2 Diesel	c		
U2 ProS	c	c	c
U2 MobileS	c	c	c
U2 MobileONE™	c	c	
* Substrate classification Porous: Paper, cardboard, sponge, untreated woods, etc. Semi Porous: Waxed surfaces, coated paper, plaster, concrete, etc. Non Porous: plastics, metals, varnished woods, glass, etc.			

2. ANSER Ink Jet Printer Components

This section covers detail explanation of ANSER printer components, which makes up from 3 major components include:

- 2.1 **Printer Main Unit**
- 2.2 **Pocket-sized Remote Keypad**
- 2.3 **Assembly Kit**

2.1 Printer Main Unit

U2 Smart

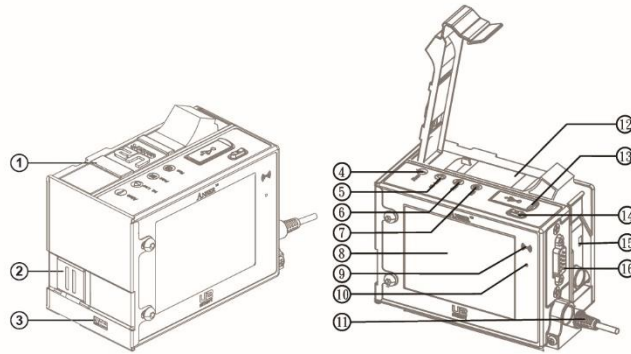

U2 SmartONE™

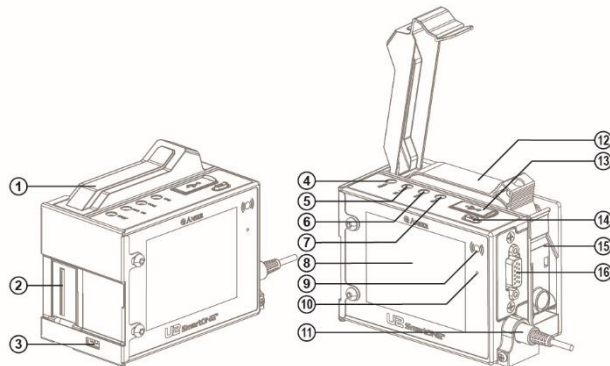

U2 ProS

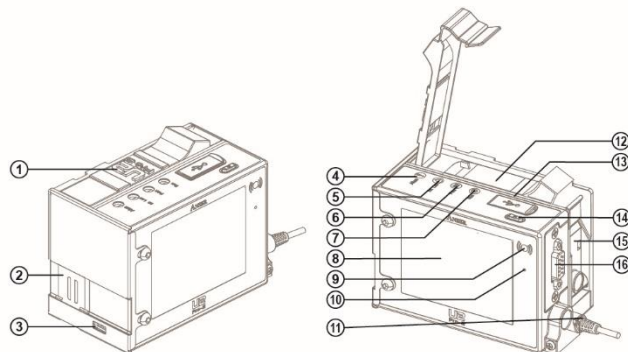

1	Dust Cover	Help to protect cartridge from getting damaged in harsh environment.
2	Print Head	The printhead uses the ink supplied by the ink bag to print the text and graphic characters on a product.
3	Built-in Photocell	Sensor that senses object and trigger printing function.
4	Alarm LED	LED will light up when cartridge has an error, no cartridge inserted, and no ink.
5	Ink Low LED	LED will light up when ink low.
6	Print LED	LED will light up during printing mode.
7	Run LED	LED will light up while power is connected
8	Display Screen	3.5-inch color LCD screen display options or printing content.
9	Infrared Receiver	Receives the infrared signal of the remote control.
10	Infrared Receiver Light	When it can receive signal indicator will light up.
11	Power Port	Connects AC adapter and power supply plug with its port.
12	Ink Cartridge	Ink cartridge containing ink.
13	USB Port	Port where USB can be connected
14	Infrared On-Off Switch	Infrared signal receiving switch button.
15	Cartridge Latch	Plug for fixed cartridge
16	RS485 Port	Port to connect alarm kit and external devices.

2.2 Pocket-size Remote Keypad

U2-Smart/U2-SmartONE"/U2-ProS can be operated by ANSER's remote keypad

U2 Printer Special Remote Control

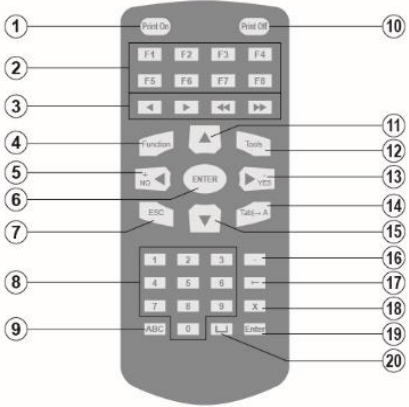

1	Print On Key	Start printing.
2	Shortcut Editing Keys	Existing Message content that contains; Time/Expire/Counter/Shift/Logo/Barcode and String. Operator can quickly access to the editing page to modify a specific content.
3	Cursor Tab Keys	These buttons allow you to move your cursor faster when creating new message.
4	Function Settings key	Shortcut to system settings page.
5	Arrow Keys	The arrow keys allow the operator to navigate through the software menus.
6	Enter Key	Confirm, save or apply a setting.

7	ESC Key	ESC key has multiple functions, and it allows operator to perform the following tasks; 1. Exit to main page 2. Go to previous page 3. Cancel a task
8	Alphanumeric Input Keys	To input alphabets and numbers when creating/editing a message.
9	Alphanumeric Switch Key	To switch between alphabets and numbers when creating/editing a message.
10	Print Off Key	Stop printing.
11	Arrow Keys	The arrow keys allow the operator to navigate through the software menus.
12	Tools Key	Shortcut to system status page.
13	Arrow Keys	The arrow keys allow the operator to navigate through the software menus.
14	Tab Key	Message delay quick access key.
15	Arrow Keys	The arrow keys allow the operator to navigate through the software menus.
16	Symbol Key	To select symbols when creating/editing a message.
17	BackSpace Key	Delete a single letter/number from the right.
18	Delete Key	No Function.
19	Enter Key	Functionality same as ⑥.
20	Space Key	To create a space to separate words.
* Battery Specification : CR2025		

2.3 Printer Assembly Kit

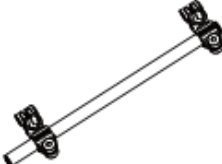
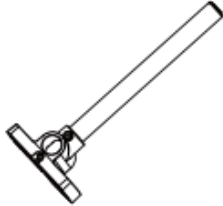
U2 Printer Assembly Kit					
1		2		3	
1	Anti-shock Clamp	Absorbs and dissipates the vibration caused by the passing printing object.			
2	Clamps and Round Bars	It allows you to install your printer in both horizontal and vertical print directions			
3	Base Clamp	It secures the printer tightly to prevent movement or separation.			

3. Installation

This section will cover brief introduction of:

- 3.1 Printer Mounting Direction**
- 3.2 Cartridge Insert & Remove**
- 3.3 Printer Startup & Shutdown**

3.1 Printer Mounting Direction

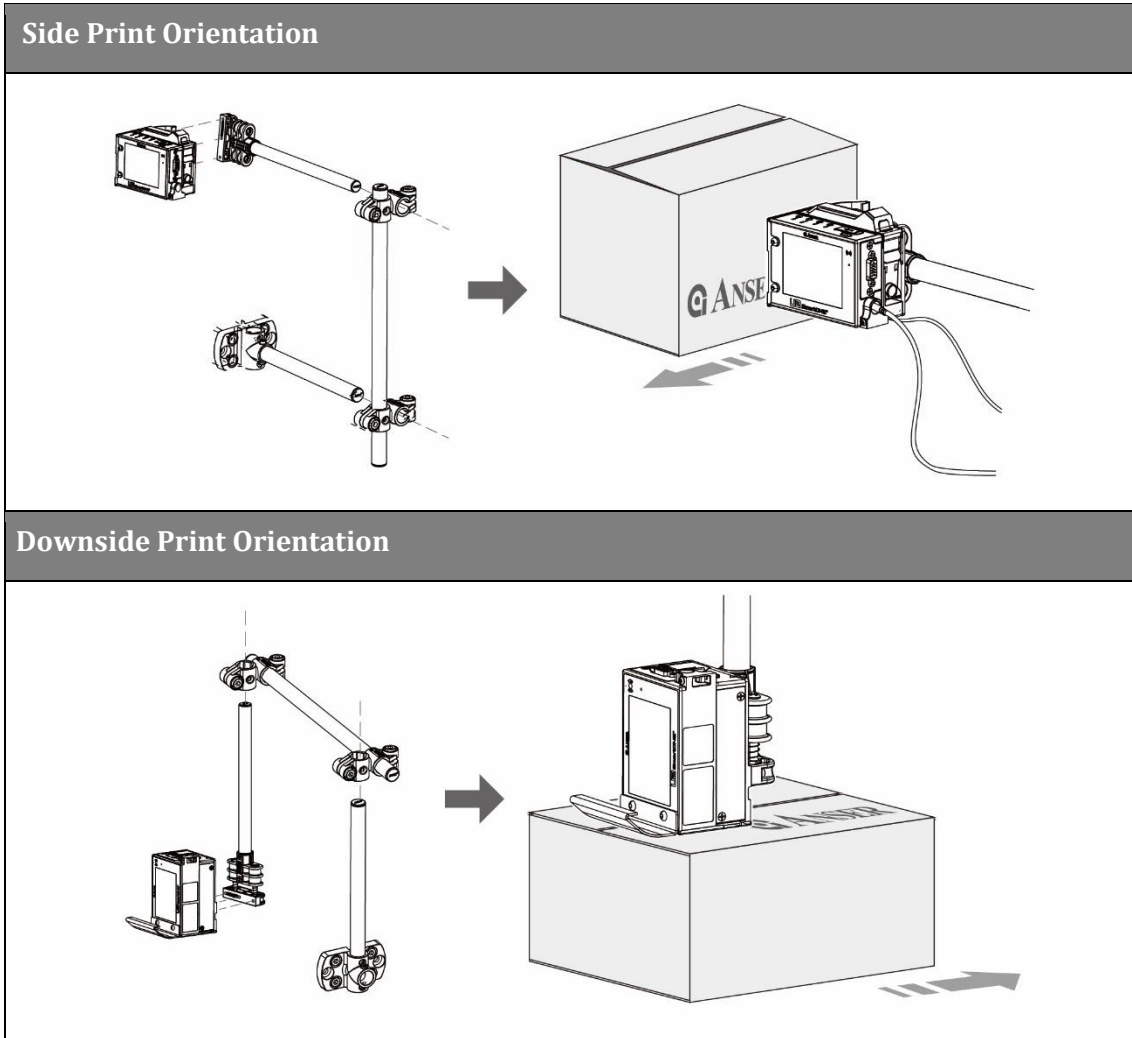

▲ Installation Consideration

Installation Consideration	
<p>1</p> <p>The distance between object and printer must be 1-3mm.</p>	<p>The diagram shows two scenarios. On the left, the printer is mounted on a box, and a blue arrow indicates a 1-3mm gap between the printer's nozzle and the top surface of the box. On the right, the printer is mounted on the side of a box, and a blue arrow indicates a 1-3mm gap between the printer's nozzle and the side of the box. Below these is a double-headed arrow in a box, indicating the range of distance.</p>

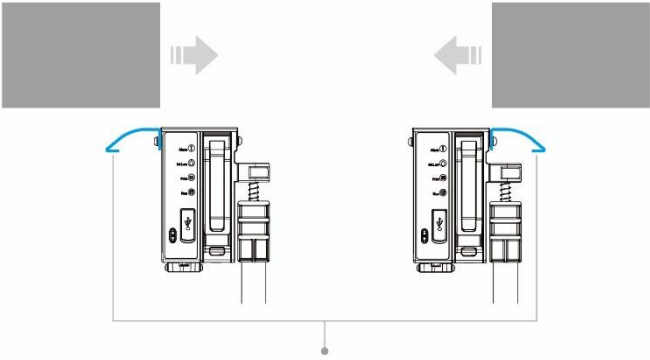
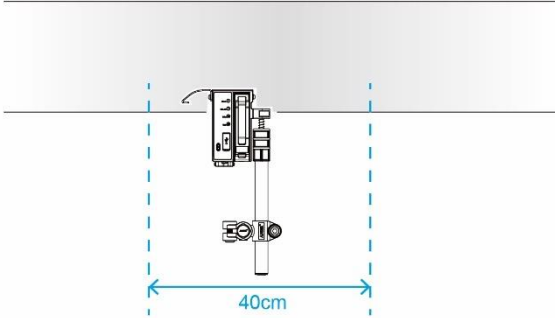
<p>2</p>	<p>Anti-shock plate should be installed according to the direction of the moving object.</p>	
<p>3</p>	<p>Keep a working area of at least 40 cm to facilitate on-site personnel to operate and maintain the equipment.</p>	

3.2 Cartridge Insert & Remove

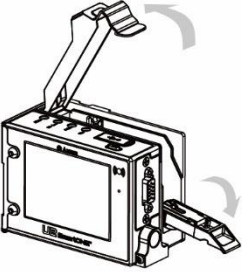
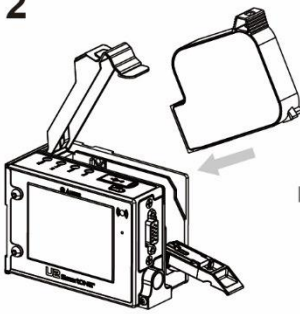
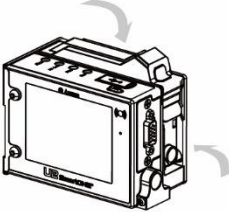
Inserting the Cartridge	
<p>1</p>	
<p>2</p>	
<p>3</p>	
<p>1</p>	<p>1. Open the dust cover on the top of the printer.</p>
<p>2</p>	<p>Insert the ink cartridge into the printer at a 15-degree angle and then press it down.</p>
<p>3</p>	<p>1. Close the latch on the rear of the printer. 2. Close the dust cover on the top of the printer.</p>

Remove Ink Cartridge from Printer

* Please make sure the printer is idle (printing off) before removing ink cartridge from printer.
 * Always cap your cartridge when it's not used. And, store the cartridge properly.

1	1. Open the dust cover on the top of the printer. 2. Open the latch on the rear of the printer.
2	Remove the ink cartridge from the printer at a 15-degree angle.
3	1. Close the latch on the rear of the printer. 2. Close the dust cover on the top of the printer.

3.3 Printer Startup & Shutdown

3.3.1 Printer Startup

CAUTION: Only use the power adapter provided by ANSER.

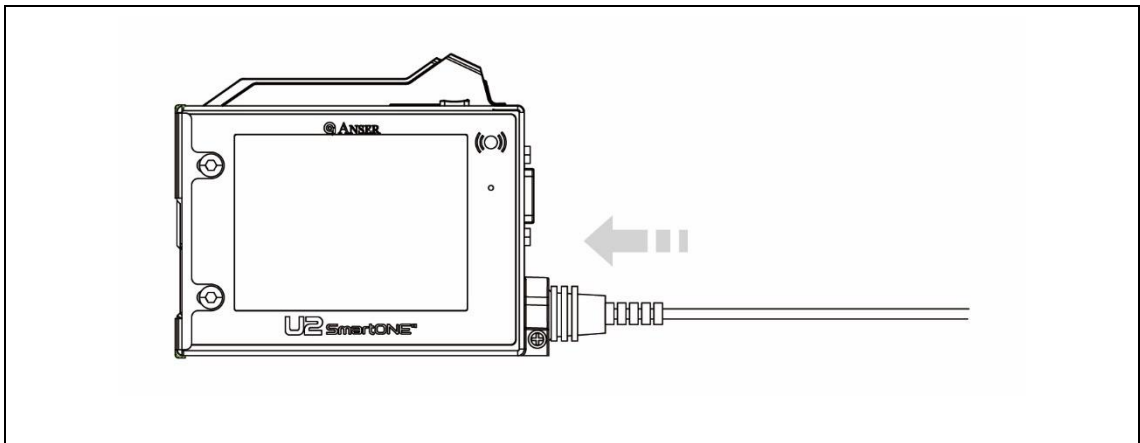

Plug the power adapter into the 12VDC socket and plug the power adapter into a wall outlet, or the power source.

3.3.2 Printer Shutdown

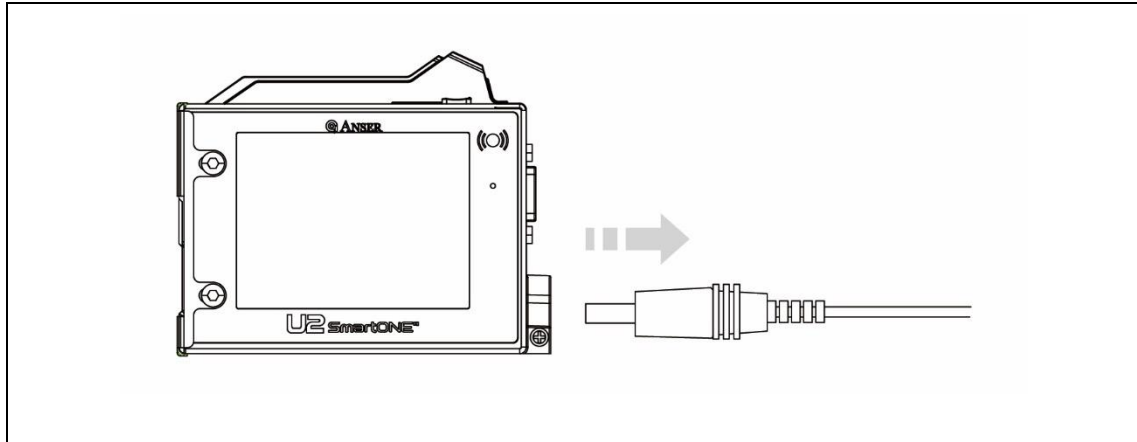

CAUTION: Please make sure printer is idle (printing off) before unplugging the power adapter, to prevent damage to the printer and ink cartridge.

For handheld version startup & shutdown, please refer to quick user guide that comes in the package.

4. User Interface Operation

This section covers detail explanation of ANSER printer user interface:

4.1 Home Page

4.2 Menu Settings Page

4.3 Editor

4.4 Editor Settings

4.5 System Settings

4.6 Function Tree

Before start operation in U2 printer, please make sure infrared receiver is turn on (bright IR LED light). If no, please press the infrared switch button to turn it on.

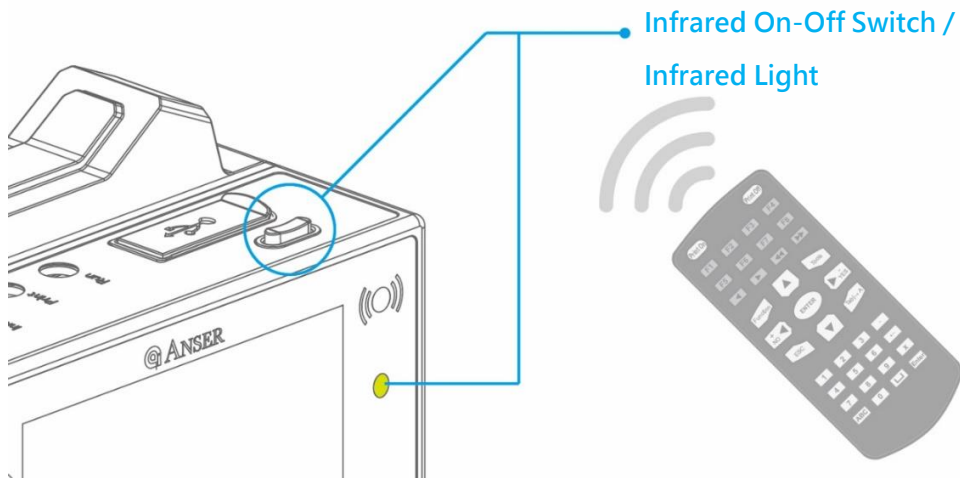

4.1 Home Page

U2 Printer main page is divided into three sections: system status, print preview and real-time printing report. The functions are as follow:



U2 ProS System Main Page











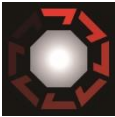



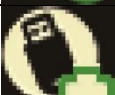









1	System Status	Display current hardware device status, print status, external hardware and device memory time, etc.
2	Print Preview	Preview real-time printing message.
3	Real-time Printing Report	Instantly display print related information, such as counters, number of prints, etc.

4.1.1 Status Bar

Provides the user's current device status, including print status, USB status, external photocell status, external encoder status, ink status, battery (**handheld only**) and system time, for each function diagram see the table below for instructions.

U2 Smart / SmartONE™ Status Bar

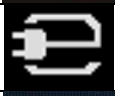
U2 ProS Status Bar

	Status Name	U2 Smart / SmartONE™	U2 ProS	Description
1	Printing Status			It shows whether the current printer is performing printing task. During printing, the icon rotates otherwise remains still.
2	USB Status			USB port is connected to a storage device in the original format.
				USB port is connected to USB WIFI dongle.
				USB port is connected to USB Ethernet dongle.
				USB port is connected to USB keyboard
				No USB connected or detected.
3	External Photocell			External photocell enabled; this function needs manual setup.
				External photocell not enabled.
4	Encoder Status			Encoder enabled; this function needs manual setup.
				Encoder not enabled.
6	Cartridge Status			Cartridge already inserted.
				Ink cartridge detection abnormal or does not exist.
	Battery			Power adapter connected, charging battery. (Only handheld version)
				Battery level (only handheld version)
	System Time	Display printer current system time.		

4.1.2 Print Preview

Present the printing content that the printer is about to/is printing.

Print Preview



Display the message that the printer is about to print, and when the message length exceeds the screen display area, the remote control  can be used in the system main screen.

4.1.3 Real-Time Printing Report.

Presents current device related printing information, such as ink consumption, counter status, printing serial number content, etc.

Real-time Printing Report



1	Product Counter	Count the number of prints done since the first print.
2	Counter, Box, Lot	When message content contains counter information, display the printing content.
3	Surplus	Display ink cartridge residual ink volume and estimated number of prints.
	Datetime	When message content contains date time related information, display the printing content.

4.2 Menu Settings Page

In U2 printers home page,  can be used to call out the menu settings page, and use the left and right direction keys and enter key to select.

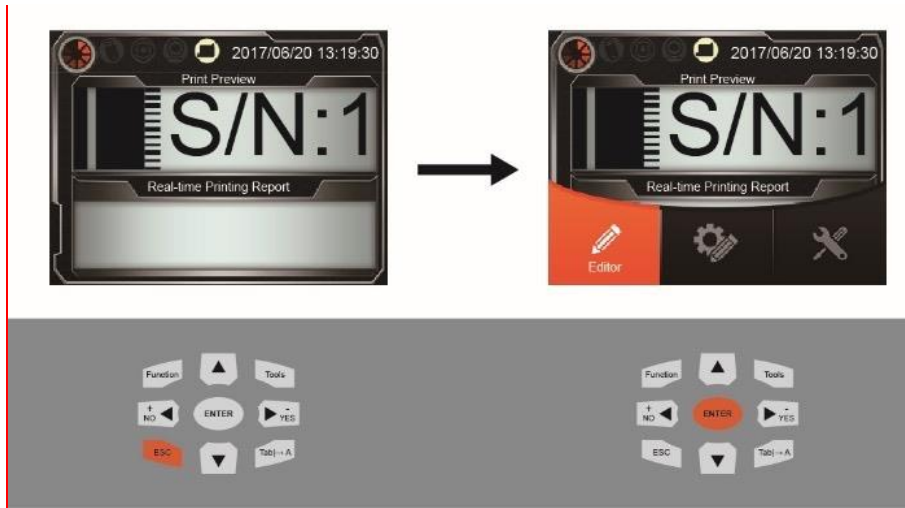





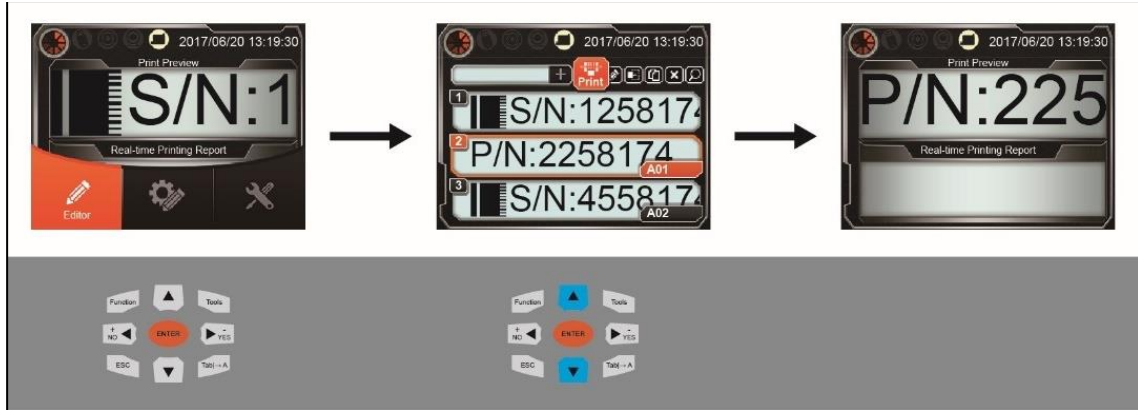

4.3 Editor

From U2 printer main menu select “Editor “to enter message list interface. User can use the operation bar to add, delete, edit, etc., printer memory information. The detailed functions are as follow:







4.3.1 Message Selection and Printing

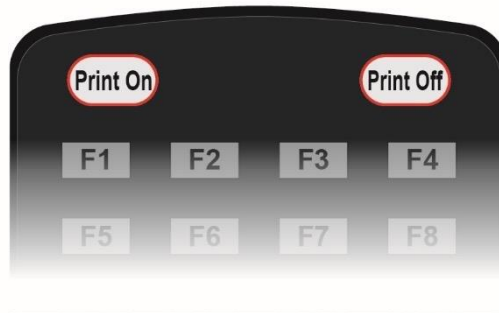

In the message list   select and print the message  , after selecting, system will automatically return to main screen and start printing. After selecting the message, you can also use remote control keys  ,  to perform print start/stop operation.



4.3.2 Adding New Message

In the message list screen can use remote control  ,  select  to enter add new message page. The page contains 3 blocks: Message preview, message name and message objects. When adding a new message you can edit the message name first and then select message object by pressing  and enter to edit the message object.



Before adding a new message, user needs to first set the message mode to free mode or line mode (support 1-4 lines). The free mode will not limit the height and placement of the message object. The line mode will fix the height of each message object to maximum height and line them up equally, and the position is aligned with the upper edge of each line. After setting completed, will enter to the new message object page. Message editing mode is introduced in the next chapter.



Free Mode



Line Mode

4.3.3 Edit Message

U2 Printer constructs the message that the user needs to print in an object-based manner. Edit message page have 5 actions can be performed: Add, edit, move, delete and edit message name.

Add Message Object



User commonly used printing content is integrated into eight “message objects” for user editing: Text, production date, expiry date, counter, shift, logo, barcode and string. Each object is described below:

a. Text

Text such as product name, description text and any text can be received as fixed text content in every print. The font of text object can be Arial or gothic, and the parameter settings include: font size and angle (0°, 90°, 180°, 270°).

b. Time / Expire

The current time information stored internally can be used to create manufacture date or expiry date according to the set validity period. This feature allows users to edit 30 type of time formats including: year, month, day, time, minute, second, Jewish day, number of weeks, week, AM/PM and custom symbols.

c. Counter

U2 printer internally have 3 types of counters: General counter, box counter and lot counter. Every counter has four parameters that can set: Maximum value, minimum value, start value (current value) and increment value. When the counter reaches maximum value, it will automatically return to minimum value, where the box counter also causes the lot counter to carry.

d. Shift

The work shift table divides the day into several time periods, and each time slot has a shift name. For example, if the current time is 09:14, the content corresponding to shift would be AAA, then the object will be printed as AAA. The system support setting 24 groups as limit.



e. Logo

Select the image object, the source of image can be imported from Message Pro using USB and then imported into the system. The supported format is bmp black and white image file. The image size supports up to 150 pixels height and 6400 pixels long (542 mm).

f. Barcode

U2 printer supports editing static text in barcodes, such as CODE-128 barcode content as text. If you need to print dynamic barcode content, you can use the Message Pro II to generate. The supported barcodes as listed in below table:

	Name 1	Name 2	Description
1	EAN8		
2	EAN13		
3	EAN14		
4	DUN14		
5	EAN128		
6	UPCA		
7	UPCE		
8	CODE39		
9	CODE128		
10	ITF14	SCC-14	
11	NVE18	SSCC18	
12	C25INTER		INTER25
13	CODABAR		
14	PDF417		
15	DATAMATRIX		
16	DMATRIX 8*32		
17	QRCODE		
18	GS1 QR Code		
19	GS1 DataBar		
20	GS1 DATAMATRIX		
21	GS1 Data Bar Exp		
22	Aztec Code		

g. String





U2 printer system enables users to set their own strings, such as: company name, URL, etc., for users to quickly edit messages. The system supports up to 5 string groups.

Edit Message Object



Move Message Object



After each message object is edited, it will enter the message preview screen, and remote control keys     can be used to adjust the position of the object.



Edit Message Name



4.3.4 Message Delay

The setting of printing delay of a single message. U2 Printer system has built-in three type of printing delays: Repeat printing delay, global delay and message delay. When the three settings are in conflict with each other, the system determines the priority as “Repeat printing delay”>” Global delay”>” Message delay”. The difference between these three delays is described below:

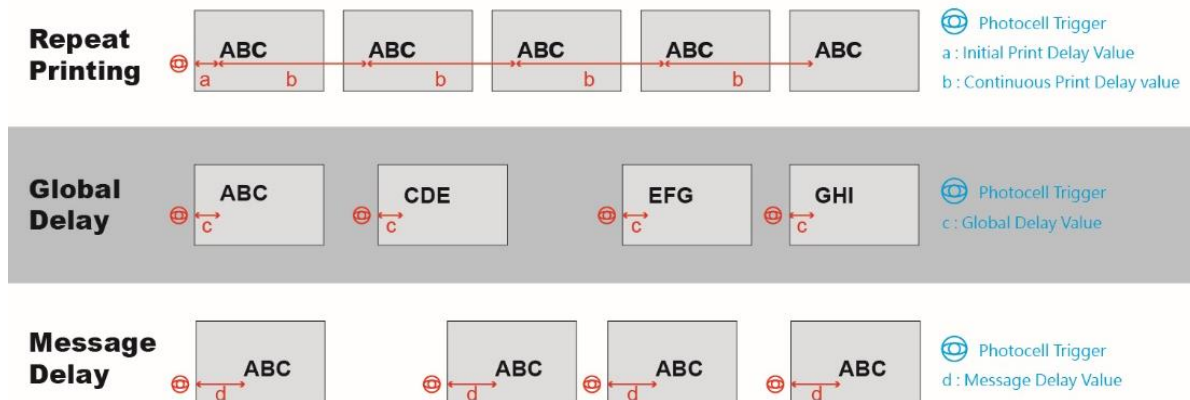

Repeat printing delay : From “System Settings”→ “Printhead” can perform setup. Setting values contain “Initial print delay” and “Continuous print delay”.

Global delay : From “System Settings”→ “General” can perform setup.

Message delay : From “Edit”→ “delay” can perform setup.

4.3.5 Copy Message

Makes a copy of system internal message. The message number can be the minimum empty value selected automatically by system or be customized by the user.

4.3.6 Delete Message

Delete system internal message. After deletion, the message code will be left blank and not automatically filled.

4.3.7 Search Message

Reduce the time of message search by searching for user-defined messages in the system by message name.



4.3.8 Loop Message

Set up to ten messages into a loop printing cycle without needing to use print on for each message.

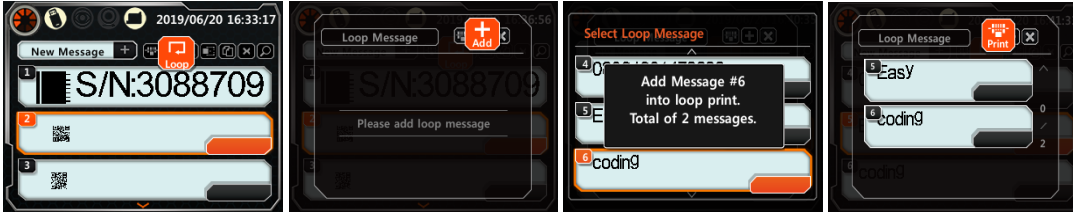

4.4 Editor Settings

The “Editor Settings” main menu can be used for “Global shift table”, “Global string table”, “Pre-zero format” and “Custom year” to improve the efficiency of message editing. Functions are described below:

4.4.1 Global Shift Table

Shift objects within a message can be edit by going through “Main menu” → Global Shift Table” to the editing page.

4.4.2 Global String Table

String objects within a message can be edit by going through “Main menu” → “Global String Table” to the editing page. String source can be either from manual input, excel file or using Net-Protocol. Set the data *string source* parameter accordingly.

4.4.3 Pre-Zero Format

When setting system printing dynamic values, the rendering of meaningless characters before numerical values, there are three items can be set: Time, date and counter as show in the following table:

	Time (Actual Time am 01:08:06)	Date (Actual date 2018/01/05)	Counter (0~999 · present value 8)
Fill 0	01:08:06	2018/01/05	008
Align Left	1-:8-:6-	2018/1-/5-	8--
Align Right	-1-:8:-6	2018/-1/-5	--8
Compact	1:8:6	2018/1/5	8

4.4.4 Custom Year

Custom year have two features, one to set custom year and one to set roll over date time. Additionally, here also can find settings for customizing

Custom Year: If this value is set as 107, the printing year will be change to 0107.

Rollover Hour: User-defined rollover date time setting, for example: Rollover time set as 23:50, current date time as 2018/01/05 23:52, then the system will automatically go forward one day printing 2018/01/06 23:52.

Month Abbreviation: Allows user to customize the name of the month used for time and expire message objects - a maximum number of 10-character set for each month.

Note: Month abbreviation feature is only supported in latest software version.

4.5 System Settings

When U2 printer software system is running, while on main menu or message page can press



to enter system settings page. There are 6 items in the system settings: General settings, printhead settings, device settings, display settings, sound settings, and printer status.

4.5.1 General Settings

General settings are for **setting** the basic values of the system, setting items are as follow

Language

U2 Printer supports 20 different languages: Traditional Chinese, Simplified Chinese, Japanese, Korean, English, German, Portuguese, Spanish, Russian, French, Italian, Turkish, Hungarian, Slovak, Czech, Switzerland, Romanian, Polish, Serbian, Bulgarian.

Measurement Units

Select British imperial (Inch) or Metric system(millimeter)

Password Setup

When the password function is turned on, every time printer is power on will prompt to enter password so as to record usage. The system allows up to 5 sets of user password to be set. System default Administrator password: 1234, Please manage and keep it safe.

Font

U2 printer system has built-in two types of fonts Arial and Gothic. System also provides custom fonts for usage. User can use USB to import custom fonts and select from the “custom fonts” menu.

Global Delay

The print delay applies to all messages in the printer. When the global delay has been set, printer will ignore message delay value and use the global delay value as the main parameter. See 4.3.4

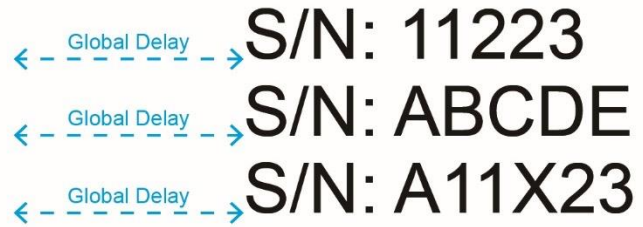

Time Zone

Set coordinated universal time (UTC)

Daylight Saving

Set daylight saving function:

Daylight Format	Description
Always ON	Current set time plus one hour
Auto	Automatically determines when daylight saving starts and ends

System Time

Adjust current system time: (Year/month/day H:M:S)

Log Report

Function	Description
Clear Log	Clear the content of the log file.
Backup Log	Before backing up, please make sure the USB is plugged into printer. Back up the log file to USB://auprn/u2d/report.log Back up the log file to USB://auprn/u2s/report.log
Export / Import Settings	Before using, please make sure the USB is plugged into printer. Export settings to USB file or import from USB into system
Export / Import Message	Before using, please make sure USB has been inserted Export all messages to USB file or import from USB into system.

Restore Default

It will reset all setting values to factory default, but user-defined message will be completely retained.

4.5.2 Printhead Settings

Printhead settings sets the values of cartridge printhead, setting items are described below:

Print Mode / Nozzle

When set to standard allow selecting either left or right nozzles. In HD print mode, both rows of nozzles are used at the same time producing a darker image.

Direction

ABC→ : Printing from left to right,

←ABC : Printing from right to left,

↻ABC : Rotation 180° from left to right,

↻ABC : Rotation 180° from right to left.

Horizontal Resolution

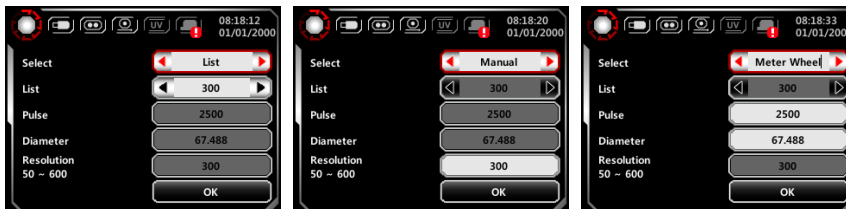

Encoder Off

System support range: 50~600 DPI (50 DPI per step). DPI value can be selected from the list or input manually.

Encoder On

- 300 DPI encoder system support: 150 DPI, 300DPI.
- 400 DPI encoder system support: 200 DPI, 400DPI.

Note: Handheld only support 400 DPI setting to match its encoder wheel.

DPI value can be selected from the list, input manually or calculated by input encoder wheel specifications.

Pre-Purge

System pre-purge is a pre-spray for the equipment's standby state to keep the nozzle moist. Humidity can be set (1~5), the more dryer the environment (or the more volatile the ink), the greater the setting value should be.

Repeat Printing

The printer **continuously** prints the same message according to the setting content, setting content as below:

Options \ Content		Setting Content	
Trigger	Off	On	On
Option	-	Infinite Printing	Finite Printing
Count	-	-	0-65535
Initial Delay	-	0-5548mm	0-5548mm
Pitch	10-5548mm	10-5548mm	10-5548mm
Use	Auto repeat printing	Photocell trigger, infinite number of prints	Photocell trigger, finite number of prints

Real Time Refresh

Print **time** related information, the frequency of the update time. Can set instant refresh (follow system time) or set time interval update (setting range: 1~9 minutes).

Clean Nozzles

Used **when** ink is stuck or clogged at the nozzles. It requires triggering the photocell to activate clean nozzles process.

4.5.3 Device Settings

Devices settings include the settings of photocell, encoder, WIFI and Ethernet settings items are as follow:

Photocell Source: it can be external or internal, system default is internal. After photocell is installed, user must manually set external option.

Photocell Mode: trigger photocell mode can be positive or negative edge trigger.

Encoder: after encoder is installed, user must manually set external option and user should choose printhead resolution same as the encoder when using external encoder.

Conveyor Speed: input current conveyor speed, or use “**Test**” to determine the average of speed of the moving object when photocell is triggered. This function is only available when **encoder** is off.

Box Width: set target width (Unit: mm)

Wireless Network: set the settings related to WIFI connection. This feature is only enabled when USB to WIFI dongle is connected.

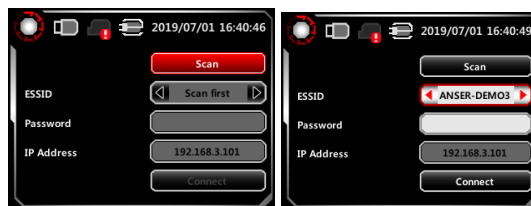

Ethernet: set the settings related to Ethernet connection. This feature is only enabled when USB to Ethernet dongle is connected.



4.5.4 Display Settings

Set the brightness of the LCD screen, time value of screensaver, and LCD test.

Screen Brightness: set screen brightness, range 1~10.

Screen saver: screen saver time, range 1~60 minutes.

LCD Test: after **enabled**, LCD will display R(red), G(green), B(blue), W(white) each one second.

4.5.5 Sound Settings

Set counter alarm, **keypad** tone and printing beep. User can also detect buzzer through check sound option.

4.5.6 Printer Status

The current software and hardware version, distributor code, ink, cartridge and system alarms related **information** can be queried in the status function.

Printer: display **printer** S/N, software and hardware version information.

Ink: display ink **volume**.

Cartridge: display **cartridge** type and printing information.

Alarm: display **system** errors.

4.6 Function Tree

Printer's system has three main functions: "Edit", "Editor Settings" and "System Settings". System function tree is as follow:

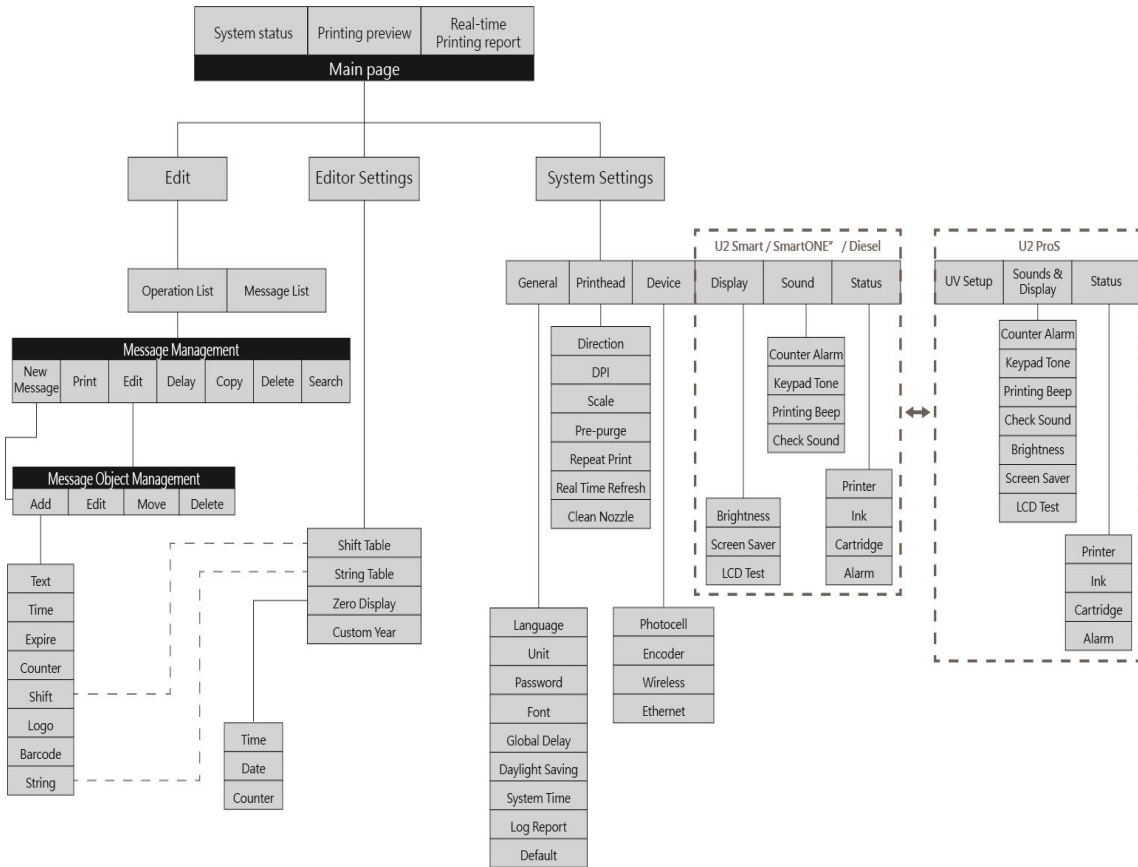

5. Additional Printer Operations

This section covers additional operations:

- 5.1 Printer Software Update**
- 5.2 RS232 Data Management**

5.1 Printer Software Update

Updating By USB

1. Copy the .ans file into firmware folder on the auprn→firmware USB directory.
2. Stay at the main page of printer interface and insert the USB.
3. Follow the on-screen instructions.
4. Please wait 90 seconds then disconnect and reconnect the power cable.

Note: If the instruction does not appear automatically after 10 seconds, re-insert the USB.

Latest Firmware versions don't require removing power cable. Printer restart automatically.

5.2 RS232 Data Management

It is possible to print information from external machines transmitting data via RS232 (PLC, scanner, checkweigher). RS232 data can be processed as a single string or split into five different string objects. RS232 port and data management settings page are by default not displayed in printer user interface, and input code is required to enable the settings page.

5.2.1 RS232 Port Settings

While staying in printer homepage, using remote control to input code 180811 to bring up RS232 port settings page.

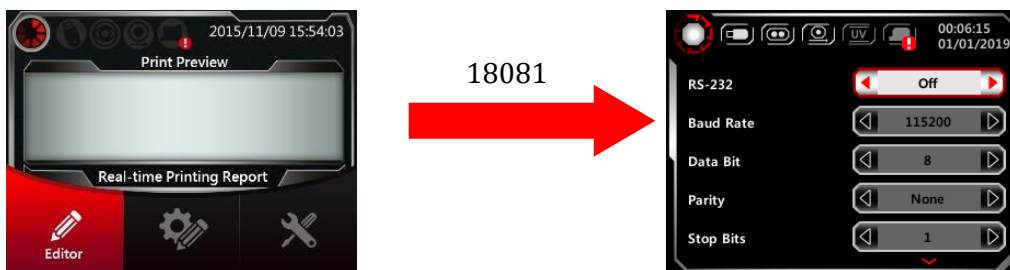

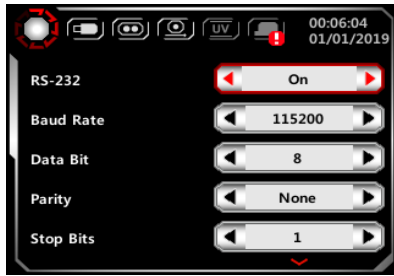

Parameters	Options
RS232	1. On 2. Off (Default)
Baud Rate	9600, 19200, 38400, 57600, 115200 (default)
Data Bit	1. 7 2. 8 (default)
Parity	1. None (default) 2. Odd 3. Even
Stop Bits	1. 0 2. 1 (default)
Flow Control	None (no support other options)
Ok	Press OK to save settings

5.2.2 RS232 Data management

While staying in printer homepage, using remote control to input code 180931 to bring up RS232 data management settings page.

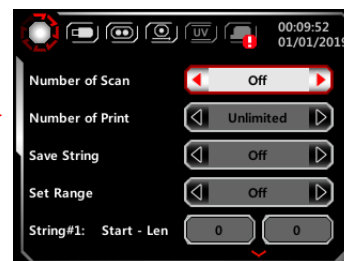

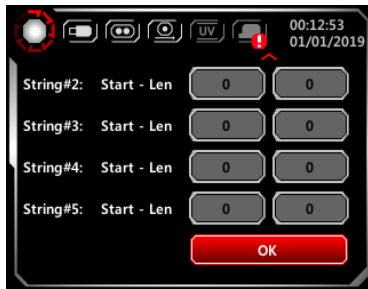
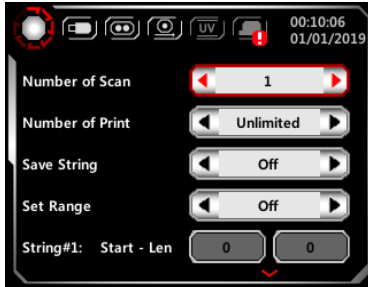

Parameters	Options
Number of Scan	1. 1 (default) 2. 2~5 no support "Set Range"
Number of Print	1. Unlimited (default) 2. 1-50
Save String	1. On, save to string table 2. Off (default)
Set Range	1. Off (default) 2. On, split RS232 data into different strings
String#1~5	"Start" position of the data for string # and "Len" number of characters
Ok	Press OK to save settings

6. MessagePRO II PC Client Software

This section covers operation of PC software:

- 6.1 USB Sync Function**

- 6.2 Edit Message**

- 6.3 Software Description**

MessagePRO II is a proprietary software which can be paired with U2 2nd series printers. It provides complete and powerful editing functions and USB can be used to exchange messages and software updates.

6.1 USB Sync Function

Please use the supplied U2 exclusive USB. If you need to use your own USB flash drive, first time using USB, while on printer's main page insert USB to perform format.

6.2 Edit Message

1. Insert the formatted USB into PC.
2. From MessagePro II, open and edit messages in the USB directory.
3. After finish editing, insert the USB back into the printer.
4. Printer will ask "Import and overwrite from USB", press "Yes "to import all message into printer.

Notice

1. When messages are synchronized, fonts and images are automatically imported into the system.
2. When messages are synchronized, all internal messages in the printer will be overwrite.
3. When messages are synchronized, time and date format, shift table, string table, custom year, zero display formats (time/date/counter) in the configuration file will also be imported into the system.

6.3 Software Description

For detailed instructions on MessagePro II, please refer to MessagePro II user manual.

7. Optional Accessories

This section covers information related to external accessories that can be connected to U2 printers:

- 7.1 External Photocell**
- 7.2 External Encoder**
- 7.3 Alarm Kit**
- 7.4 Photocell and Encoder Installation**
- 7.5 Sensors and Alarm Kit Installation**

U2 printers can support external photocell, encoder and warning light, their specifications and installation method are described below:

7.1 External Photocell

Provide more reliable and precise sensing parameter

If internal photocell cannot be used because of printing position, please connect external photocell.

Installation

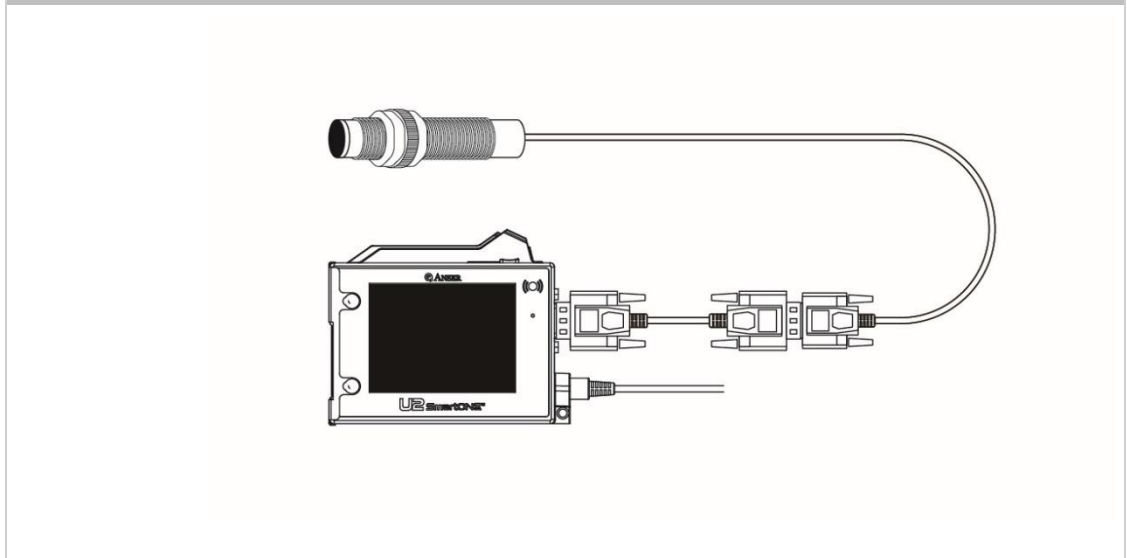

7.2 External Encoder

Provide high print quality on unstable conveyor

Encoder detects the line speed so that printer can print correctly. Need to be set in a place where can detect the same speed as the movement of the product.

Installation

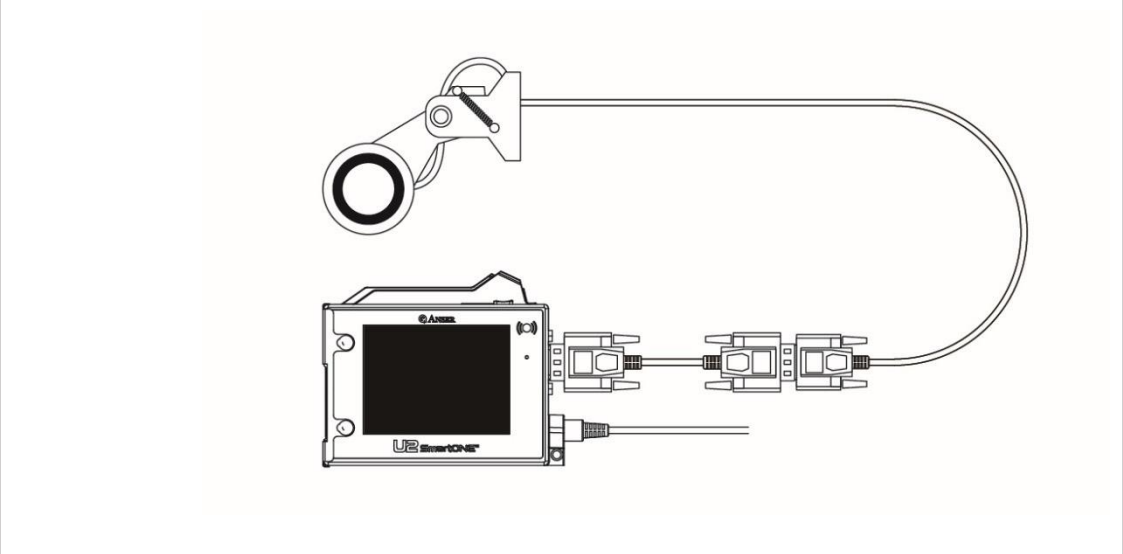

7.3 Alarm Kit

Alert users in the event of an incident, warning light needs to be pair up with the Smart I/O expansion kit to be used.

Installation

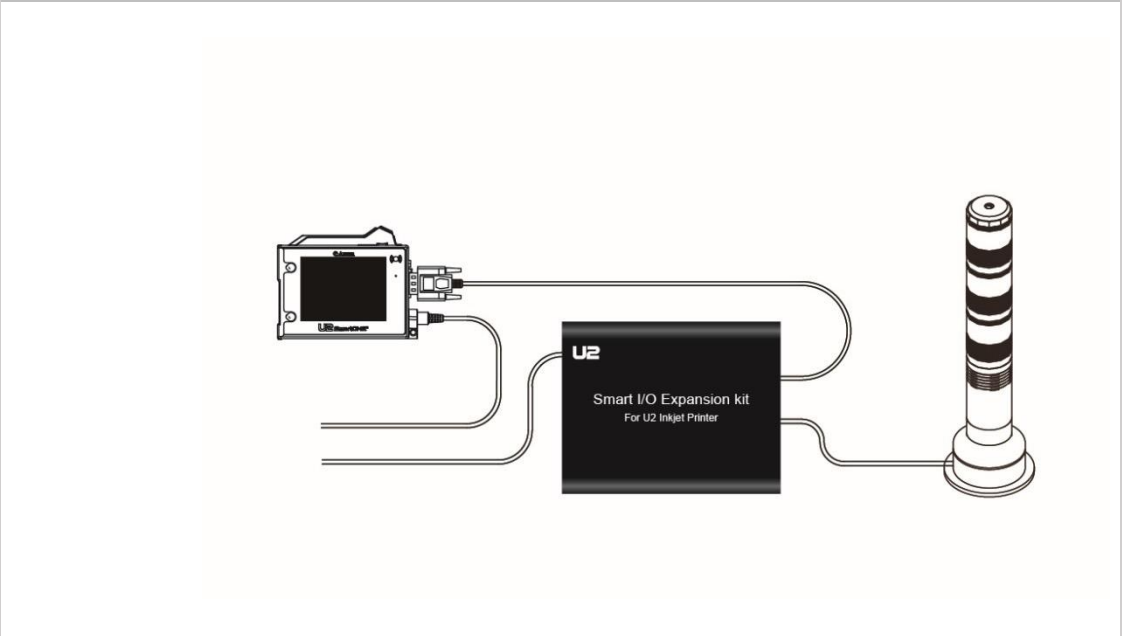

7.4 Photocell and Encoder Installation

When both photocell and encoder need to be installed together please use Y-cable, as shown in the following figure:

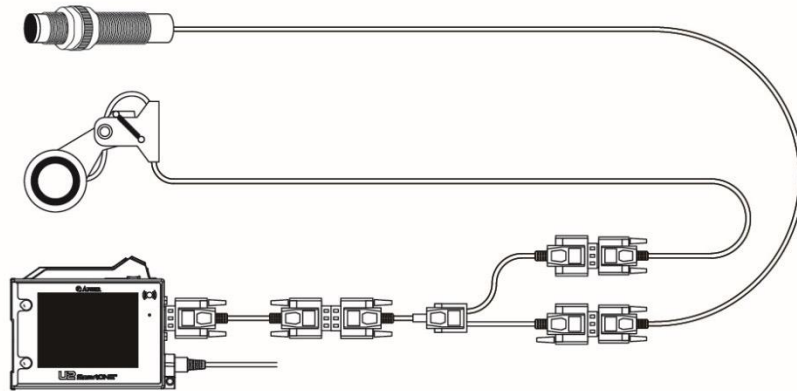

7.5 Sensors and Alarm Kit Installation

When need to install warning light, photocell and encoder all at the same time, please use the expansion kit. The installation is shown in the following figure:

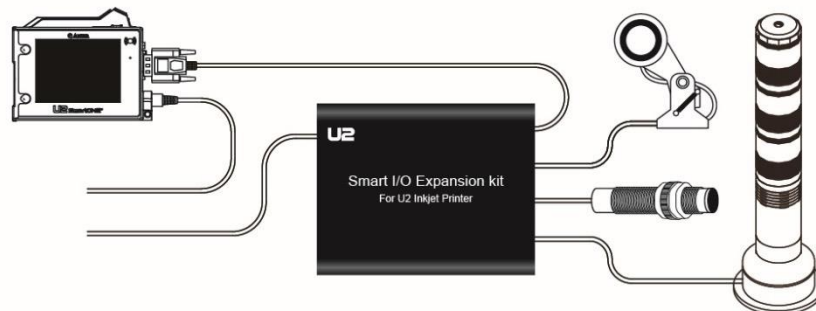

8. Daily Protection and Maintenance

This section covers important information regarding the daily maintenance of both printer and cartridges:

- 8.1 Cartridge Maintenance**
- 8.2 Periodic Time Adjustment**
- 8.3 Printer Maintenance**

For normal use, the following daily maintenance operations are required:

8.1 Cartridge Maintenance

To ensure print quality, the following maintenance is required:

Uptime Maintenance

During uptime, put the special wet towel on the wiping board, gently wipe the cartridge nozzles part, gently wipe the ink cartridge with a width of about 10 cm.

Downtime Maintenance

1. Downtime less than 1 hour does not require special maintenance. However, the printed product may be subject to deviation due to the use environment. If there is any deviation in the printed product, please put the special wet tissue on the wiping board, gently wipe the nozzle part of the ink cartridge, and gently wipe the ink cartridge with a width of about 10 cm.
2. Downtime more than 1 hour, please stop printing mode and then perform uptime maintenance.

Long Downtime

When downtime more than 2 days, remove ink cartridge from the printer and cover the printhead with the protective clip and placed in a special collection box for proper collection.

8.2 Periodic Time Adjustment

To avoid system time variation, it is recommended that the user periodically correct the system clock. In particular, when you need to print date or time of production and expiration date. Please be sure to adjust the system time once a week.

8.3 Printer Maintenance

Cleaning of printer may become necessary when working on dusty environments that could cause accumulation of debris on both printer and cartridge.

Please use isopropyl alcohol dampened lint-free moist cloth and gently clean the pen board electrical pins and DISC module pins.

9. Troubleshooting

This section covers topics related to the functioning of the printer:

9.1 Encoder Setting Problem

9.2 Photocell Setting Problem

The following is the recommended troubleshooting procedure when the user encounters a fault on the printing. When abnormal printing occurs in the printer, you can follow the steps below to perform simple troubleshooting. If the user cannot solve the problem according to procedure, please contact distributor or the manufacturer for technical support.

9.1 Encoder Setting Problem

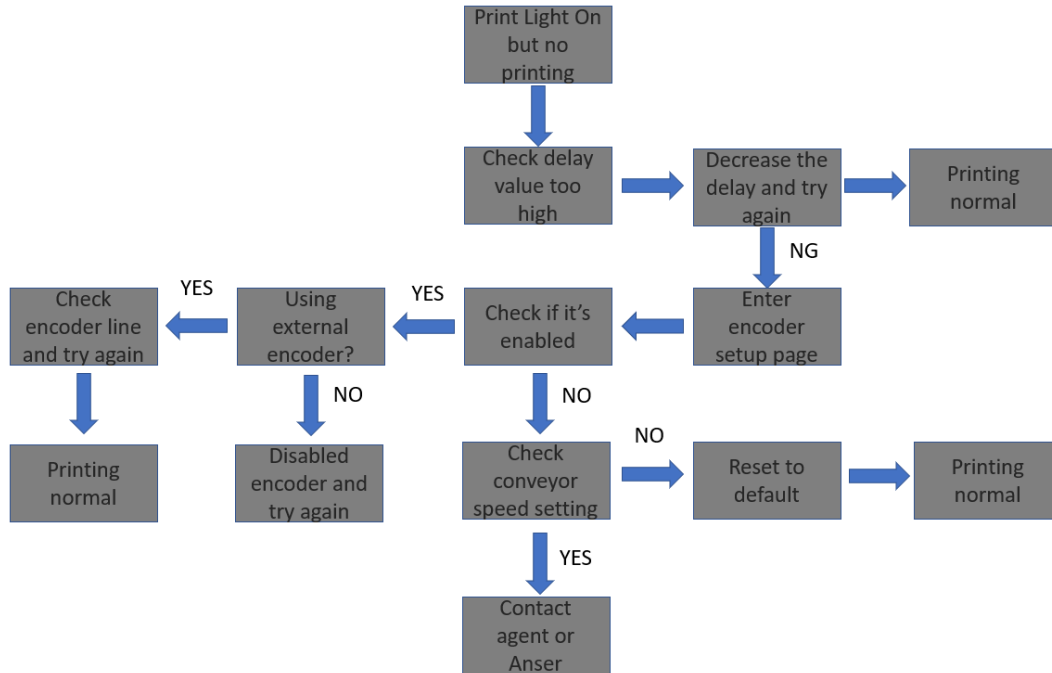

9.2 Photocell Setting Problem

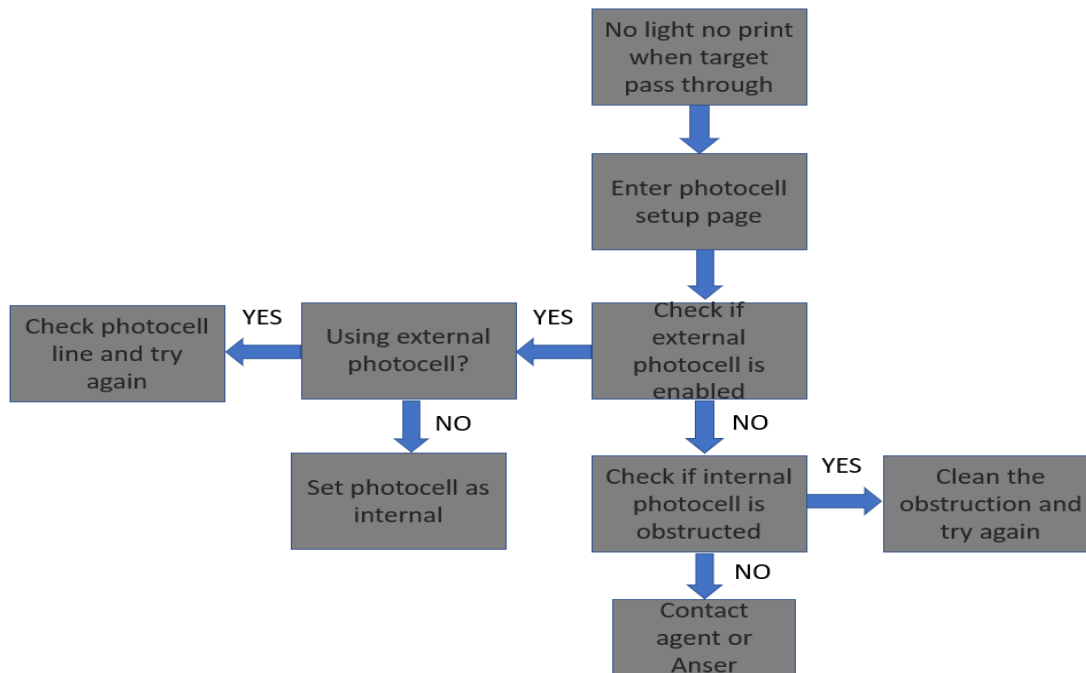

10. Specification

This section covers information related to the technical specifications of printer and external accessories:

10.1 U2 Inkjet Printer

10.2 External Photocell

10.3 External Encoder

10.4 Alarm Kit

10.5 Expansion Kit Box

10.1 U2 Ink Jet Printer

Printer	
Warranty Period	All U2 series printers have 15 months warranty starting from the shipping date
Display	3.5" color screen, display screen 320x240 pixels and backlight display
User Interface	Offline operation (no computer connection required)
	Group network printing via personal/tablet computer
Input Device	Pocket-sized IR remote keypad
Available Languages	English, Japanese, French, German, Spanish, Portuguese, Russian, Korean, Italian, Turkish, Hungarian, Slovak, Czech, Swedish, Romanian, Polish, Serbian, Bulgarian, Chinese (Traditional & Simplified)
LED Indicators	Alarm, ink Low, Print, Run, Remote on/off
Dimensions	119 x 78.8 x 76 mm
Weight	550g
Printing Orientation	Horizontal or downside
Operating Temperature	5°C-40°C (41°F-104°F)
Data Interface	RS-485, USB HOST
Power Specifications	
External power supply	AC input 100V~240V, 50/60Hz
	DC output 12V, 5A ; total 60 W
Optional Accessories	
External Encoder	High quality printing is ensured when the conveyor speed is unstable
External Photocell	Provide external photocell to increase installation convenience
External Warning Light	The indicator light can be connected externally to facilitate timely detection of faults.

10.2 External Photocell

Specification	
Dimensions	D×H : $\Phi 22.0 \times 72.0$ (mm)
Cable Length	1.9m + 0.24m (9-pin 15-pin conversion cable)
Sensing Distance	300mm below
Content Items	
Photocell	1
9-pin 15-pin conversion cable	1
Screw to adjust sensitivity	1
Line mounting bracket	1
Bracket for controller installation	1
Screw	2
Washer	2
Nut	2

10.3 External Encoder

Specification	
Wheel Diameter	49.7mm
Resolution	300 or 400 DPI
Cable Length	1.9m + 0.24m (9-pin 15-pin conversion cable)
Content Items	
Encoder	1
9-pin 15-pin conversion cable	1
Encoder mounting bracket (main)	1
Encoder mounting bracket (horizontal)	1
M6×L20 screw	8
M6 washer	8
M6 Nut	8

10.4 Alarm Kit

Warning Lamp body

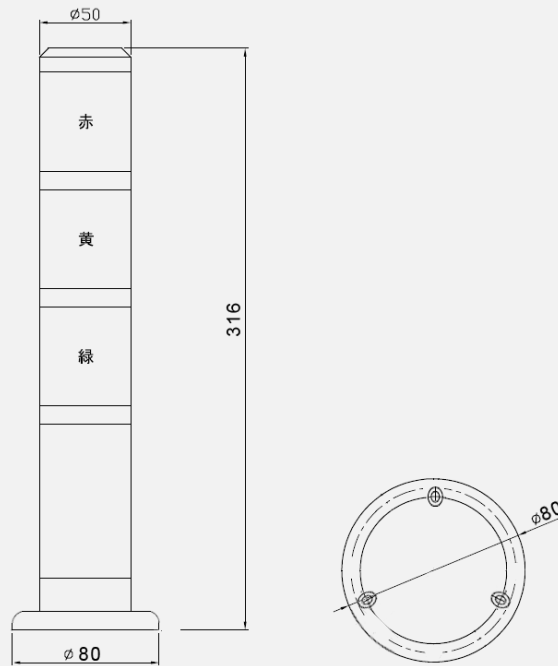

Dimensions

D×H : Φ80.0×316.0 (mm)

Weight

600g

Signal Pattern

Red light, yellow light, green light, warning beep

Cable Length

3.0m

10.5 Expansion Kit Box

Expansion Kit Box

Red Light	No ink, no cartridge, unknown cartridge
Yellow Light	Low ink
Green Light	Printing Mode (can print)
Alarm BEEP	No ink

Output Input Terminals

11. Installation / Operation Precautions

This section covers information related to precautions that should be consider during installation and operation of printer:

11.1 Installation Precautions

11.2 Operation Precautions

11.1 Installation Precautions

1. The printer must be equipped with an anti-collision mechanism and tighten all screws after installation. In the absence of an anti-collision mechanism for the nozzle, any external damage suffered (such as a box impact nozzle) is not covered by the warranty.
2. Please remove the cartridge at a 15-degree angle.
3. Users are strongly advised to ground the power supply, and should avoid sharing power with large power equipment such as motors.
4. If there is too much dust in the working environment, it is strongly recommended to use an air compressor to remove internal dust.

11.2 Operation Precautions

1. When the printing result is blurred, please confirm that the distance between the nozzle and the object remain within 5mm for the best print distance.
2. When ink trailing occurs in the print, please wipe the surface of cartridge nozzle with the special wipe.
3. If the printing position is not correct, please press the [Tab|→] button on the remote control to set the optimal printing position.
4. By default no action after 30 seconds will activate the screen protection mechanism. The screen will automatically turn off, press any key in the remote control to restart the screen.
5. If the printer appears cannot solve the fault, please contact the distributor.
6. Warning: Operation of this equipment in a residential environment could cause radio interference.



WWW.ANSER-CODING.COM